

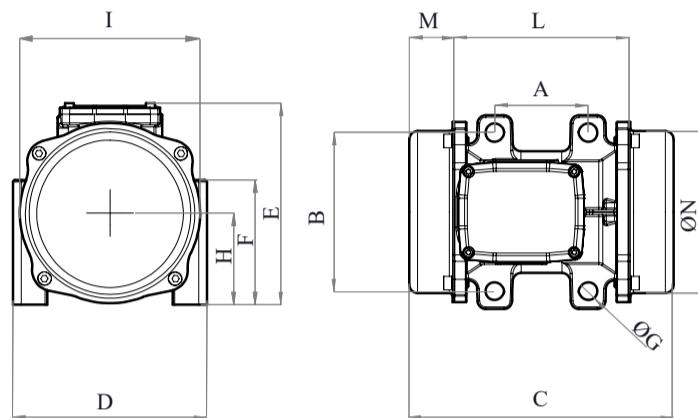

# MVE 1530/6N-HF-38E0 [EN40153038E0BA0000]

3 PH - 4 poles - 6000 RPM - 220-240/400-460 V - 200 Hz

Working moment (Kg*cm)	Unbalance (Kg*cm)	Centrifugal force (Kg)	Nominal voltage (V)	Input power (kW)	Current (A)	Power Factor	Ia/In
6,82	3,41	1.384	220-240/400-460	1	Δ 2,8 Y 1,62	0,89	



OVERALL DIMENSIONS (mm)													
Weight (Kg)	A	B	G	Holes number	C	D	E	F	H	I	L	M	N
12	90	154	18	4	255	187	195	121	89	174	169	43	156

TECHNICAL FEATURES						
Type of grease	Greased for life	Screw	Washer	Clamping torque (Nm)	Cable type	Cable gland
/	Yes	M16	17 x 30 mm	210	4G2.5 80°C	M25 120°C

BEARINGS				
Bearing model	Type	Life 100%	Life 80%	Life 50%
6306 2Z		/	/	/

CERTIFICATION	
Atex II 3D Ex tc IIIc Tx IP66 [Tx Size 10-30:100°C - Tx Size 40-91:135°C] T.Amb -20/+40°C	